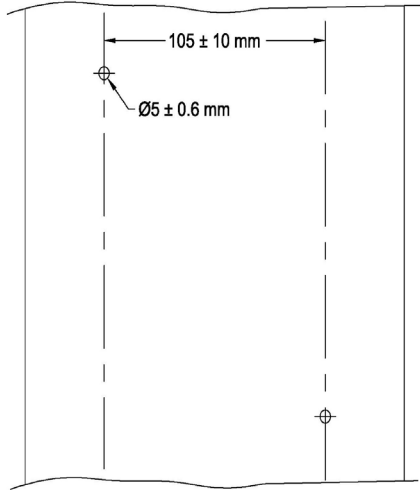

# SPÉCIFICATIONS TECHNIQUES / TECHNICAL SPECIFICATIONS

K3M 11 x 7.10-5

## PNEUMATIQUE / TYRE

### 5" SLICK – K3M REAR

Manufacturier / <i>Manufacturer</i>	<b>MG INDÚSTRIA E COMERCIO S/A</b>
Marque / <i>Make</i>	<b>Komet</b>
Modèle / <i>Model</i>	<b>K3M – 11 x 7.10 – 5</b>
Catégorie / <i>Category</i>	<b>IAME Series</b>
Nombre de pages / <i>Number of pages</i>	<b>4</b>
La présente Fiche reproduit descriptions, illustrations et dimensions du pneumatique.	<i>This Form reproduces descriptions, illustrations and dimensions of the tyre.</i>
	
Photo du pneu monté sur la jante / <i>Photo of the tyre fitted to the rim</i>	Dessin de la bande de roulement / <i>Tread design drawing</i>

DESCRIPTIONS TECHNIQUES	TECHNICAL DESCRIPTIONS
Sous une température de 23°C +/-2°C, avec une humidité de 50% +/-5%	At a temperature of 23°C +/-2°C and with a humidity of 50% +/-5%

Pt	Descriptions / Descriptions	Valeurs / Values	Tolérances / Tolerances
1	Dimensions / <i>Dimensions</i>	11 x 7.10 - 5	--
2	Désignation du mélange / <i>Tread compound designation</i>	K3M	--
3	Pression de service / <i>Service pressure</i>	0,8 bar	+/- 0.3 bar
4	Pression de gonflage / <i>Inflation pressure</i>	4 bar	max
5	Capacité de charge / <i>Load capacity</i>	100 Kg	max
6	Vitesse maximale / <i>Maximum speed</i>	200 Km/h	
7	Rigidité latérale et verticale (sous charge de 40 kg) / <i>Lateral and vertical stiffness (under 40 kg load)</i>	L 1 mm V 7 mm	L: +/-1 V: +/-2
8			
9	Profondeur du profil / <i>Depth of tread</i>	3,5 mm	+/- 0.5 mm
10	Poids en grammes / <i>Weight in grams</i>	1550 gr	+/- 10%
11	Nombre de plis / <i>Number of plies</i>	2	--
12	Épaisseur de la bande de roulement / <i>Tread thickness</i>	3,9 mm	+/- 1.0 mm
13	Nombre d'indicateurs d'usure du pneu / <i>Number of tread wear indicators</i>	6	--
14	Matériau de la carcasse / <i>Carcass material</i>	Poliester	--
15	Angle de tissage de la toile du pneu / <i>Angle of tyre canvas</i>	31,5°	+/- 3°
16	Type de fil de tissage (selon ISO) / <i>Canvas thread type (according to ISO)</i>	1670	--
17	Pneu tubeless / <i>Tubeless tyre</i>	YES	--
18	Dureté superficielle de la bande de roulement (ISO 48:1010 – 2 échantillons de 2 mm d'épaisseur) / <i>Superficial tread hardness (ISO 48:1010 – 2 samples of 2 mm thickness)</i>	66.5	+/- 5 DIDC - IRHD
19	Contrainte-déformation en traction (ISO 37:2017 – éprouvette type 3) / <i>Tensile stress-strain (ISO 37:2017 – type 3 sample)</i>	à / at 100% à / at 300%	à / at 100% à / at 300%
		1.4 4.9	+/- 0.5 MPa +/- 0.8 MPa

**K3M 11 x 7.10-5**

<b>DESSIN</b>	<b>DRAWING</b>
---------------	----------------

Dessin du pneu en section transversale et dimensions du pneu monté sur une jante / <i>Drawing of tyre cross section and dimensions of the tyre fitted to a rim</i>		<b>Dimensions / Dimensions</b>	<b>Tolérances / Tolerances</b>
		Ø	+/- X
	A	210 mm	± 5 mm
	B	150 mm	± 10 mm
	C	202 mm	± 5 mm
	D	Ø 272 mm	± 10 mm
	E	Ø 126.2 *	+0/-1.0
*Dimension selon Dessin Technique N° 1.1 - Jante 5" / <i>Dimension according to Technical Drawing N° 1.1 - 5" rim</i>			

**DESSIN TECHNIQUE / TECHNICAL DRAWING**

Jante / Rim 5"

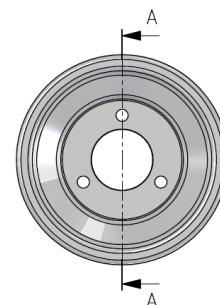
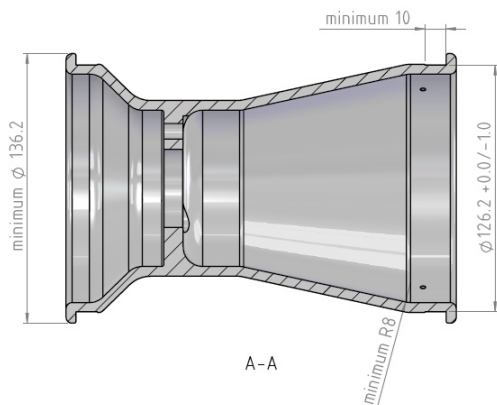

Cotes en / Dimensions in mm

PHOTOS ET INSCRIPTIONS	PHOTOS AND INSCRIPTIONS		
Photo du flanc extérieur du pneu / <i>Photo of tyre external sidewall</i>	Inscriptions sur le flanc extérieur du pneu / <i>Inscriptions on tyre external sidewall</i>		
	<b>Texte / Text</b>	<b>Hauteur / Height</b>	<b>Trait / Stroke</b>
		mm	mm
	Komet Racing Tyres (printed)	18 x 74	
	Barcode (printed)	12 x 30	
	>>> KART RACING TYRE	8,0	1,8
	11 x 7.10 – 5	9,0	2,0
	MAX INFLATION PRESSURE 4 BAR	3,7	0,8
Photo du flanc intérieur du pneu / <i>Photo of tyre internal sidewall</i>	Inscriptions sur le flanc intérieur du pneu / <i>Inscriptions on tyre internal sidewall</i>		
	<b>Texte / Text</b>	<b>Hauteur / Height</b>	<b>Trait / Stroke</b>
		mm	mm
	Komet Racing Tyres	14,0	4,5
	11 x 7.10 – 5	9,0	2,5
	K3M	10,0	2,0
	For racing purpose only . tubeless	2,8	1,0
	Barcode (printed)	12 x 30	